

| | | |
|---|---|--|
|  | <p style="text-align: center;">Nemoto Sensor Engineering Company Ltd</p> | <p>4-10-9 Takaido-Higashi Suginami-ku Tokyo 168-0072, Japan</p> <p style="text-align: right;">www.nemoto.eu</p> |
|---|---|--|

NCP-180S-6S Explosive/Flammable Gas Sensor Operating Characteristics and Handling Manual



The NCP-180S-6S is a new Catalytic (pellistor) type flammable gas sensor supplied as a matched pair of pellistor elements mounted on a single header and protected by a metal enclosure and can.

The sensor detects and measures the presence of flammable gases and vapours in air, in the range 0-100%* of the Lower Explosive Limit (LEL) of the gas or vapour being measured. Designed for use in Fixed Gas Detection Systems, we believe the NCP-180S-6S offers an unparalleled combination of high performance and low-cost.

The NCP-180S-6S exhibits excellent long term zero and sensitivity stability and a high level of resistance to catalytic poisons. The highly automated manufacturing procedure employed by Nemoto results in a repeatable reliable sensor which, unlike similar devices, requires no trimming resistor to enable the detector to be matched with a compensator.



Contents

| | |
|---|-----------|
| Principles of Operation..... | 3 |
| General Specifications..... | 4 |
| Outline Drawing and construction..... | 5 |
| Performance Measurements..... | 6 |
| Gas Sensitivity/Linearity..... | 6 |
| Temperature Dependence..... | 7 |
| Humidity Dependence..... | 8 |
| Relative Responses to Various Gases..... | 9 |
| Poison Resistance..... | 10 |
| Exposure to Overage Conditions..... | 11 |
| Shock and Vibration resistance..... | 11 |
| Storage and Operation in extreme Environmental Conditions..... | 11 |
| Notes on Sensor Testing..... | 13 |

Nemoto Sensor Engineering Company Ltd
168-0072 4-10-9, Takaido-higashi, Suginami-ku, Tokyo
TEL. 81-3-3333-7341
FAX. 81-3-3333-7344
WEB: <http://www.nemoto.eu>

Note that the Performance measurements expressed in this document should be considered as typical characteristics for guidance only, and not as specifications which are guaranteed, apart from those in the sections "General Specifications" and "Dimensions" (Pages 4 and 5). It is the instrument designer's responsibility to ensure that the sensor is suitable for any given application.

Nemoto has a policy of continuous development and improvement of its products. As such the specification for the device outlined in this document may be changed without notice.



Principles of Operation:

Catalytic combustion has been the most widely used method of detecting flammable gases in Industry since the invention of the catalysed pelletized resistor (or "Pellistor") over 40 years ago.

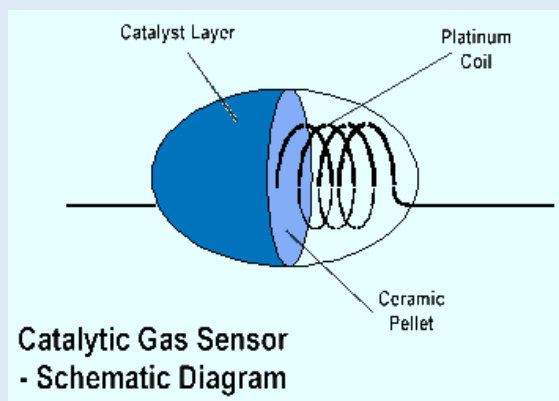

A Pellistor consists of a very fine coil of platinum wire, embedded within a ceramic pellet. On the surface of the pellet is a layer of a high surface area noble metal, which, when hot, acts as a catalyst to promote exothermic oxidation of flammable gases. In operation, the pellet and so the catalyst layer is heated by passing a current through the underlying coil. In the presence of a flammable gas or vapour, the hot catalyst allows oxidation to occur in a similar chemical reaction to combustion. Just as in combustion, the reaction releases heat, which causes the temperature of the catalyst together with its underlying pellet and coil to rise. This rise in temperature results in a change in the electrical resistance of the coil, and it is this change in electrical resistance which constitutes the signal from the sensor.

Pellistors are always manufactured in pairs, the active catalysed element being supplied with an electrically matched element which contains no catalyst and is treated to ensure no flammable gas will oxidise on its surface. This "compensator" element is used as a reference resistance to which the sensor's signal is compared, to remove the effects of environmental factors other than the presence of a flammable gas.

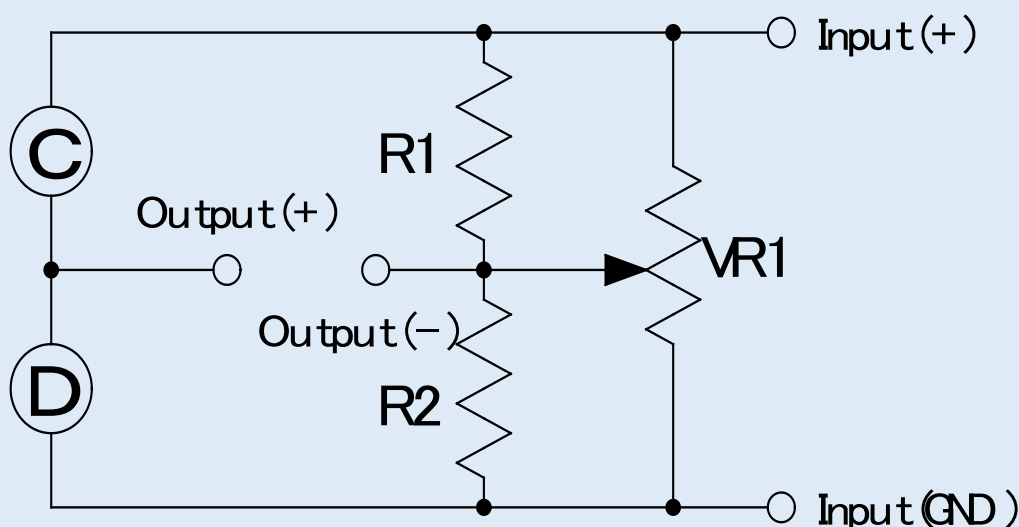

Pellistor Drive/Measurement Circuit: A simple Wheatstone Bridge to compare the resistance of two hot elements



The advantage of using this technique when detecting flammable gases for safety purposes is that it measures flammability directly.

Nemoto provides matched pair Pellistors conveniently mounted in a variety of enclosures for different applications. Some of these options contain the detector and compensator elements in separate enclosures (the NP range for Industrial applications). In the case of the NCP-180S-6S, both elements are contained within a plastic enclosure for ease of use and low cost.

Catalytic pellistor type gas sensors have many advantages compared with semiconductor type gas sensors

- ❖ Linear output in proportion to gas concentration
- ❖ Greater Stability
- ❖ Higher reproducibility
- ❖ Gas specific - will only respond to flammable gases
- ❖ Unaffected by humidity
- ❖ Stable output for long periods
- ❖ More resistant to shocks and vibrations.

General Specifications:

| Operating Specifications: | |
|--|---|
| Detected Gases | Flammable Gases (Specifications are based on the detection of Methane/Natural Gas) |
| Standard Concentration Range | 0-100% LEL |
| Recommended Bridge Voltage | 2.6V +/- 0.1V |
| Current Consumption (at Recommended Bridge Voltage) | 170mA +/- 20mA |
| Bridge zero offset | 0 +/- 30mV |
| Minimum Output Sensitivity | 20 mV for 1% CH₄ |
| Linearity | Effectively Linear to 100% LEL |
| Response Time (Measured as T90) | <10 secs |
| Accuracy (Measured as Repeatability) | ± 0.5mV for Zero ± 1% LEL for Gas Sensitivity |
| Long Term Stability Drift | Sensitivity: Less than 1% LEL / month Zero: Less than +/- 0.5% LEL / month |
| Expected Lifetime in the field | > 3 Years. |
| Warranty Period | 24 Months |
| Environmental Specifications: | |
| Temperature Range | -20°C to +60°C |
| Standard constant Humidity Range | 15 to 90%RH |
| Standard Constant Pressure Range | 1atm ± 10% |
| Recommended storage Temperature Range | 0 to 20 degree C |
| Recommended Maximum Storage Time | 6 months |
| Mechanical Data | |
| Enclosure Material | Nickel Plated Brass |
| Connector Pin Material | Nickel |
| Header (Base) Material | Phenolic Resin |



Dimensions and Structure

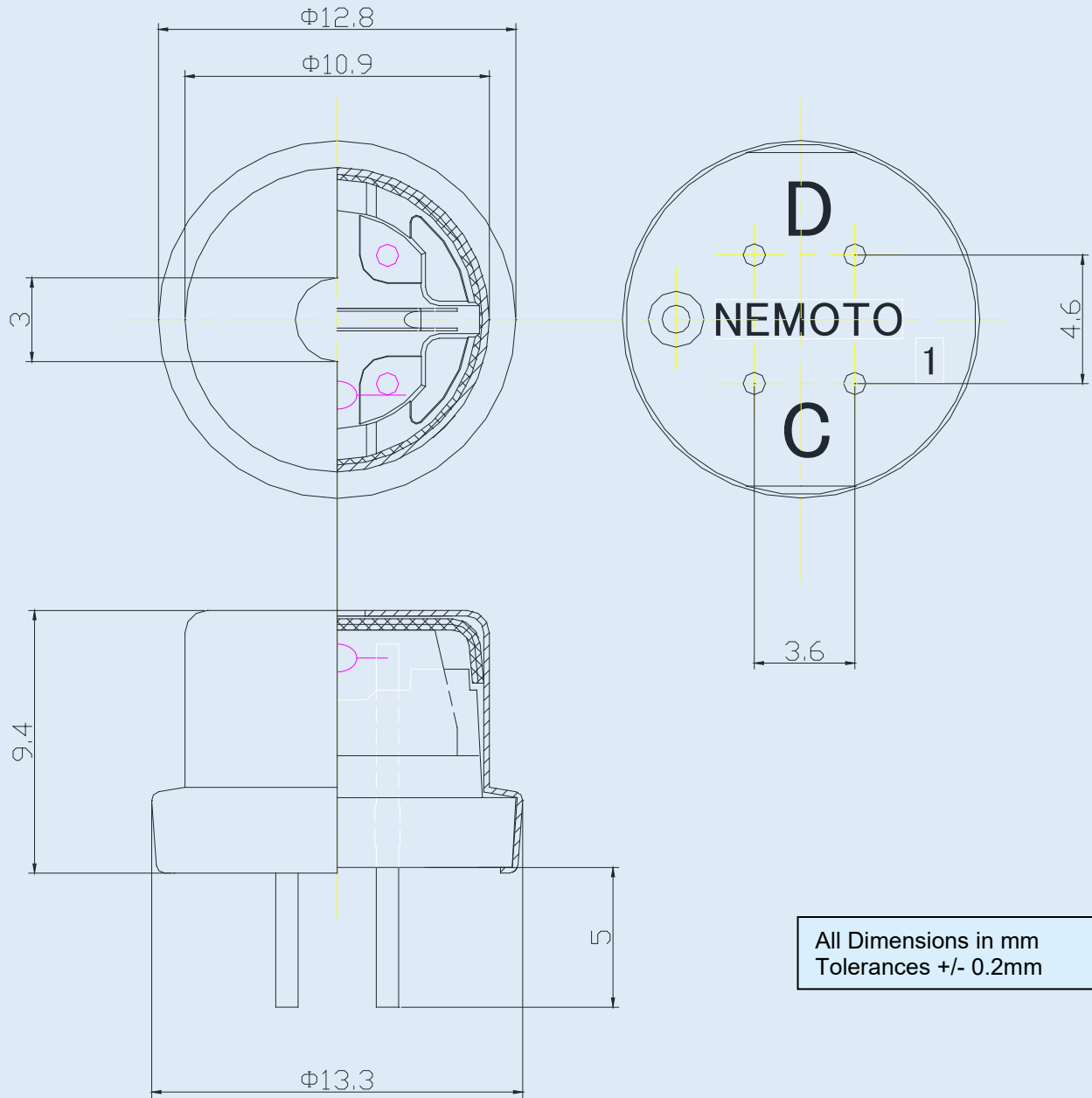

All Dimensions in mm
Tolerances +/- 0.2mm



Performance Measurements

The NCP-180S-6S sensor is derived largely from the very popular NAP-56A sensor, the main difference being in the enclosure, which has been redesigned to attain similar performance characteristics to sensors mounted in twin T04 headers. The design brief for the NCP-180S-6S sensor was to achieve these characteristics whilst maintaining the cost benefits of single header design.

The chief performance difference between the two sensors is that the signal output of the NAP-180S-6S sensor is very much lower than the NAP-56A, resulting in a wider usable range of 0-100%LEL and better linearity. To offset the lower sensitivity, steps have been taken to reduce noise effects.

Gas sensitivity / Linearity

The graph below shows the typical sensitivity characteristics for methane. One can see that the sensor is not 100% linear (as with all pellistor gas sensors), but the deviation from linearity is very small and can be compensated for in software if required. More details on linearity can be supplied on request.

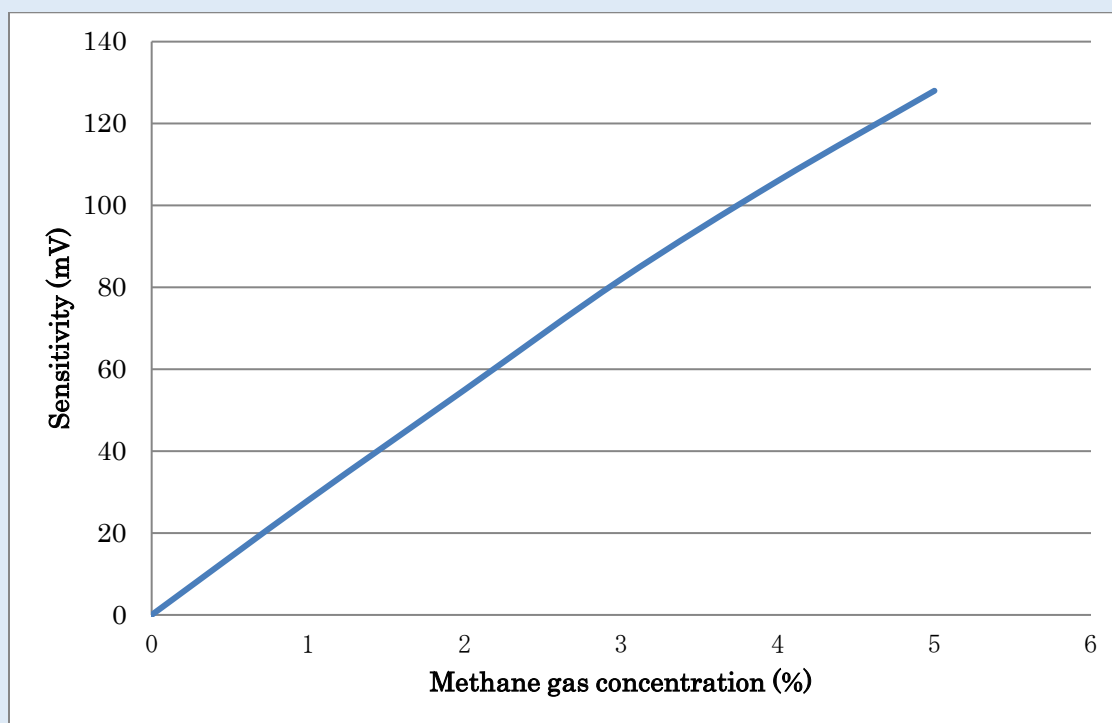



Temperature Dependence

Typical Zero Offset Drift with Temperature

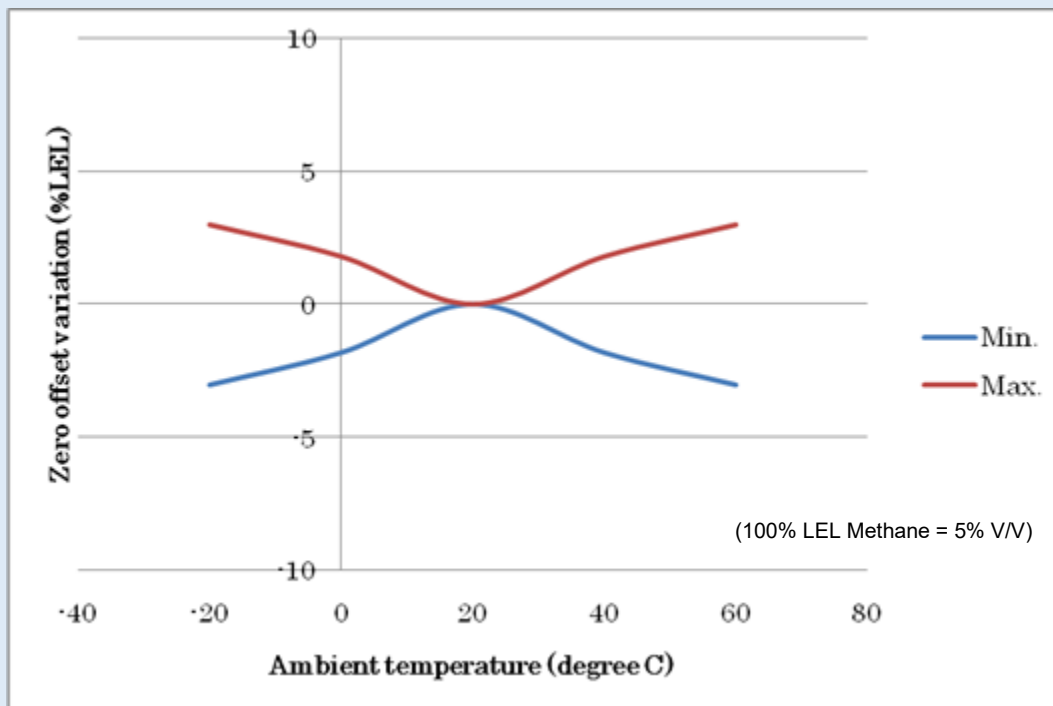

Typical Gas Sensitivity Drift with Temperature

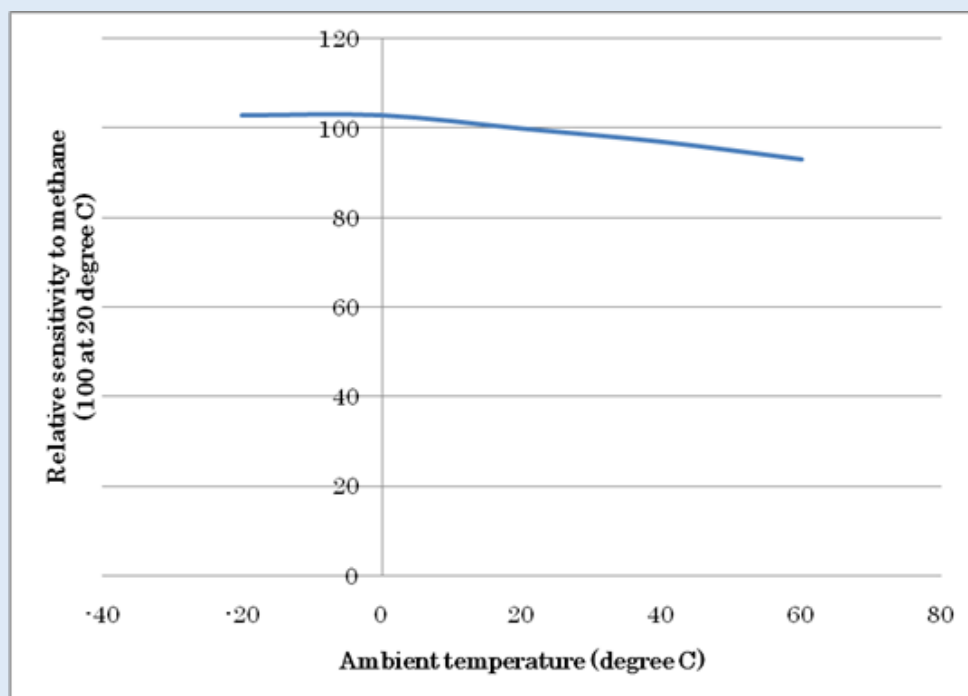

Humidity Dependence



Typical Zero Offset Drift with Humidity

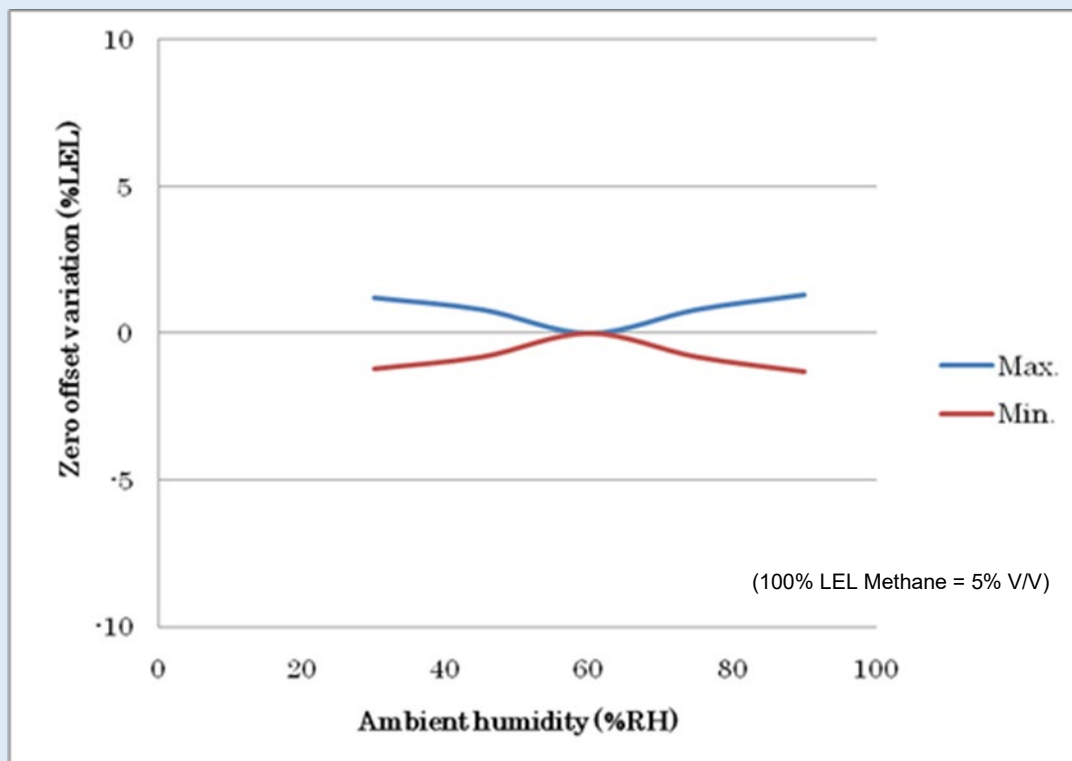

Typical Gas Sensitivity Drift with Humidity

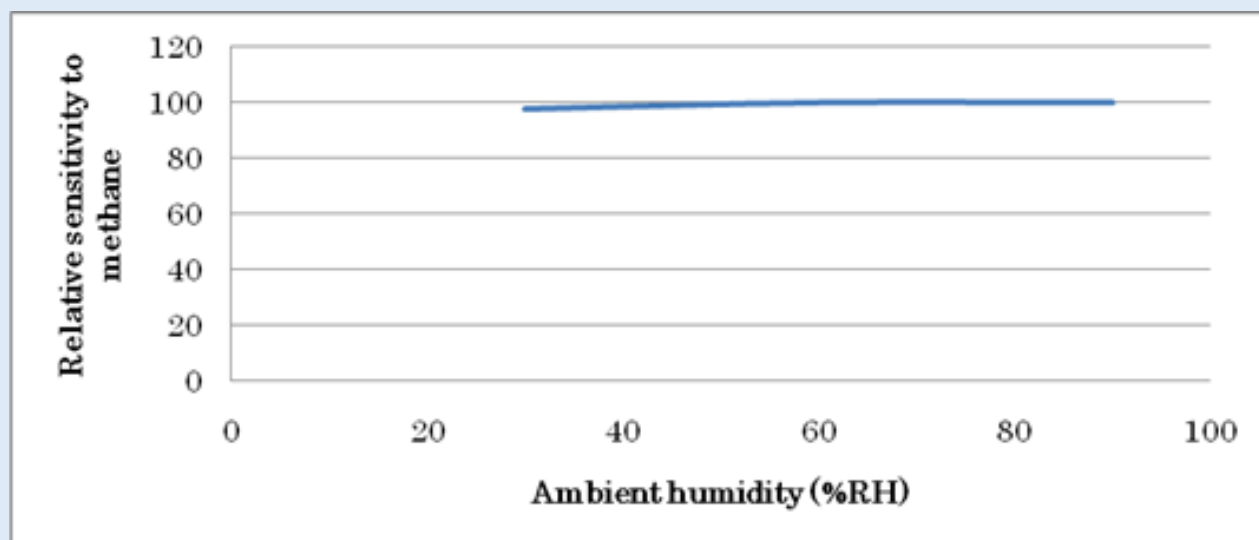



Relative Responses to various gases

Below is a table of the NCP-180S-6S responses to various flammable gases. The table assumes the sensor is measuring on the 0-100% LEL scale and assumes that the response to methane = 100%.

Note that the LEL data can be different in different countries. In Europe, the LEL's used are defined in the IEC standard IEC80079-20-1, whilst in the USA and various other areas, LELs are generally taken from the US Bureau of Mines Bulletin Document 627.

Technically, both are correct; the reason for the differences being that the measurements made for IEC80079-20-1 are with the gas in motion, whilst the US Bureau of Mines Bulletin Document 627 assumes the gas is not moving.

For convenience, relative responses are given according to BOTH standards below.

| Gas | Formula | LEL (Europe) (IEC80079-20-1) | Relative Response (%) | LEL (USA) (USBoM 627) | Relative Response (%) |
|---------------------------|--|---------------------------------|-----------------------|--------------------------|-----------------------|
| Methane | CH₄ | 4.4 | 100 | 5 | 100 |
| Acetic acid | CH ₃ COOH | 4 | 8 | 5.4 | 9 |
| Acetone | (CH ₃) ₂ CO | 2.5 | 22 | 2.6 | 20 |
| Cyclo-hexane | C ₆ H ₁₂ | 1 | 41 | 1.3 | 47 |
| Cyclo-pentane | C ₅ H ₁₀ | 1.4 | 56 | 1.5 | 53 |
| Ethanol | C ₂ H ₅ OH | 3.1 | 33 | 3.3 | 31 |
| Ethyl acetate | C ₂ H ₅ COOH | 2 | 23 | 2.2 | 22 |
| Ethylene | C ₂ H ₄ | 2.3 | 56 | 2.7 | 58 |
| Hydrogen | H ₂ | 4 | 97 | 4 | 85 |
| Iso-butane | C ₄ H ₁₀ | 1.3 | 48 | 1.8 | 59 |
| Iso-octane | C ₈ H ₁₈ | 0.7 | 33 | Not Given | 29 |
| Iso-propanol | CH ₃ -CHOHCH ₃ | 2 | 26 | 2.2 | 25 |
| Methanol | CH ₃ OH | 6 | 56 | 6.7 | 55 |
| N-butane | C ₄ H ₁₀ | 1.4 | 47 | 1.8 | 53 |
| N-heptane | C ₇ H ₁₆ | 0.85 | 37 | 1.05 | 40 |
| N-hexane | C ₆ H ₁₄ | 1 | 44 | 1.2 | 46 |
| N-pentane | C ₅ H ₁₂ | 1.1 | 44 | 1.4 | 49 |
| Propane | C ₃ H ₈ | 1.7 | 56 | 2.1 | 61 |
| Styrene | C ₆ H ₅ CH=CH ₂ | 1 | 20 | 1.1 | 19 |
| Toluene | C ₆ H ₅ CH ₃ | 1 | 31 | 1.2 | 33 |
| Ammonia | NH ₃ | 15 | 92 | 15 | 81 |
| Propylene | CH ₃ -CH=CH ₂ | 2 | 52 | 2.4 | 55 |
| Carbon monoxide | CO | 10.9 | 45 | 12.5 | 45 |
| Xylene | C ₆ H ₄ (CH ₃) ₂ | 1 | 30 | 1.1 | 29 |
| n-octane | CH ₃ (CH ₂) ₆ CH ₃ | 0.8 | 38 | 0.95 | 39 |
| Butyl Acetate | C ₄ H ₉ COO(CH ₃) | 1.2 | 14 | 1.4 | 14 |
| Iso-butanol | (CH ₃) ₂ CHCH ₂ OH | 1.4 | 28 | 1.7 | 30 |
| Iso-pentane | CH(CH ₃) ₂ (C ₂ H ₅) | 1.3 | 52 | Not Given | 46 |
| Methyl Ethyl Ketone (MEK) | CH ₃ COC ₂ H ₅ | 1.5 | 18 | 1.9 | 20 |
| n-propanol | CH ₃ (CH ₂) ₂ OH | 2.1 | 34 | 2.2 | 31 |

For other flammable gases, Nemoto can advise on the anticipated sensitivity of the sensor. Since the relative sensitivities to various gases is also dependent on the mounting arrangement within an instrument, this data should always be considered as a guide only - it is always recommended that the instrument maker determines the response of the sensor to the target gas by experiment using the final product design wherever possible.



Poison Resistance

Hydrogen Sulphide (H₂S)

Sensors were exposed in 2.5% Methane and 25ppm Hydrogen Sulphide for 1 hour. at normal temperature and humidity.

| No. | Before test (mV) | | After test (mV) | |
|-----|------------------|---|-----------------|---|
| | Zero offset | Relative sensitivity to CH ₄ | Zero offset | Relative sensitivity to CH ₄ |
| 1 | 18.9 | 100 | 20.0 | 100 |
| 2 | 10.7 | 100 | 11.8 | 96 |
| 3 | 7.5 | 100 | 8.8 | 98 |
| 4 | 20.8 | 100 | 22.5 | 98 |
| 5 | -7.4 | 100 | -5.6 | 97 |

Silicones

Sensors were exposed in 2.5% Methane and 10ppm of HMDS (HexaMethylDiSiloxane) for 1 hour. at normal temperature and humidity.

| No. | Before test (mV) | | After test (mV) | |
|-----|------------------|---|-----------------|---|
| | Zero offset | Relative sensitivity to CH ₄ | Zero offset | Relative sensitivity to CH ₄ |
| 1 | 0.5 | 100 | 1.8 | 91 |
| 2 | 27.5 | 100 | 27.8 | 93 |
| 3 | -12.3 | 100 | -12.4 | 94 |
| 4 | 1.9 | 100 | 2.8 | 92 |
| 5 | 3.7 | 100 | 4.5 | 94 |

Exposure to overrange Conditions

Sensors were exposed in 8% Methane at normal temperature and humidity for 1 hour.

| No. | Before test (mV) | | After test (mV) | |
|-----|------------------|---|-----------------|---|
| | Zero offset | Relative sensitivity to CH ₄ | Zero offset | Relative sensitivity to CH ₄ |
| 1 | 25.2 | 100 | 27.0 | 102 |
| 2 | 17.2 | 100 | 18.4 | 96 |
| 3 | 24.6 | 100 | 25.8 | 97 |
| 4 | 5.4 | 100 | 7.1 | 97 |
| 5 | 8.0 | 100 | 8.8 | 99 |



Shock

Sensors were dropped from the height of 30cm onto the wood board of 3 cm thickness with free fall. The drop was repeated 3 times.

| No. | Before test (mV) | | After test (mV) | |
|-----|------------------|---|-----------------|---|
| | Zero offset | Relative sensitivity to CH ₄ | Zero offset | Relative sensitivity to CH ₄ |
| 1 | 16.9 | 100 | 17.2 | 100 |
| 2 | -26.4 | 100 | -26.7 | 100 |
| 3 | -11.3 | 100 | -11.9 | 100 |
| 4 | 4.5 | 100 | 5.1 | 99 |
| 5 | 17.1 | 100 | 17.1 | 101 |

Vibration

A vibration of 10Hz with 4mm amplitude in all 3 directions of X, Y and Z, was applied to the sensors for 20 minutes.

| No. | Before test (mV) | | After test (mV) | |
|-----|------------------|---|-----------------|---|
| | Zero offset | Relative sensitivity to CH ₄ | Zero offset | Relative sensitivity to CH ₄ |
| 1 | 1.8 | 100 | 1.7 | 98 |
| 2 | 7.9 | 100 | 8.8 | 102 |
| 3 | 7.2 | 100 | 8.0 | 102 |
| 4 | 21.7 | 100 | 21.4 | 100 |
| 5 | 19.6 | 100 | 18.8 | 102 |

Storage in high temperature and humidity

Sensors were stored unpowered in 60 degree C, 90%RH for 1000 hours.

| No. | Before test (mV) | | After test (mV) | |
|-----|------------------|---|-----------------|---|
| | Zero offset | Relative sensitivity to CH ₄ | Zero offset | Relative sensitivity to CH ₄ |
| 1 | 15.3 | 100 | 16.2 | 100 |
| 2 | 11.1 | 100 | 12.3 | 97 |
| 3 | 17.2 | 100 | 18.5 | 95 |
| 4 | -23.9 | 100 | -23.8 | 99 |
| 5 | -22.4 | 100 | -22.4 | 99 |



Operation in high temperature and humidity

Sensors were energized in 60 degree C, 90%RH for 1000 hours.

| No. | Before test (mV) | | After test (mV) | |
|-----|------------------|---|-----------------|---|
| | Zero offset | Relative sensitivity to CH ₄ | Zero offset | Relative sensitivity to CH ₄ |
| 1 | 2.7 | 100 | 2.5 | 99 |
| 2 | 1.1 | 100 | 1.7 | 96 |
| 3 | 6.5 | 100 | 8.6 | 96 |
| 4 | -11.8 | 100 | -10.5 | 100 |
| 5 | 6.8 | 100 | 7.0 | 94 |

Storage in low temperatures

Sensors were stored at -20 degree C for 1000 hours

| No. | Before test (mV) | | After test (mV) | |
|-----|------------------|---|-----------------|---|
| | Zero offset | Relative sensitivity to CH ₄ | Zero offset | Relative sensitivity to CH ₄ |
| 1 | 24.5 | 100 | 24.1 | 98 |
| 2 | 13.4 | 100 | 14.4 | 100 |
| 3 | -29.6 | 100 | -28.1 | 95 |
| 4 | 12.7 | 100 | 13.5 | 93 |
| 5 | 5.6 | 100 | 6.2 | 98 |



Notes on sensor testing

All Nemoto specifications are based on testing within a gas filled chamber. Testing the sensor using a flow-through system will yield similar, but not identical, results. The Nemoto test set up is illustrated below:

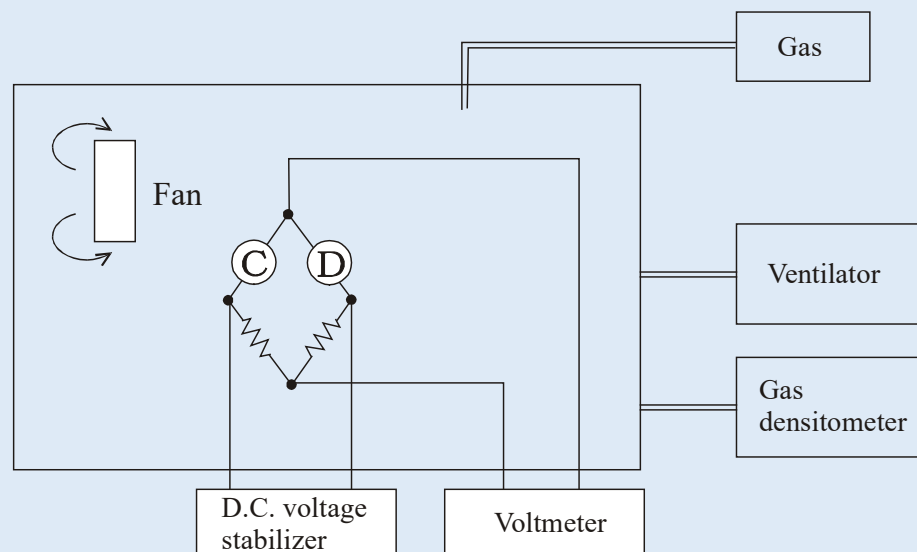

The test chamber should be constructed of glass, or another material known not to absorb gases.

In Nemoto's test regime, test gases are introduced into the chamber by injection, following careful calculation of the amount of gas required to generate the required concentration within the chamber. This may also be accomplished by purging the chamber using gas from a test gas cylinder, provided the flow rate used is not high enough to cause turbulence in the chamber.

The gas inside the chamber should be gently agitated by a slow moving fan, to ensure that concentration gradients do not develop during testing, either by stratification layers forming in the chamber, or by the consumption of the gas by the sensors themselves.